

High Performance Up - Thrust Jaw Crusher
CMC 高性能反向破碎顎碎機

www.chymeang.com

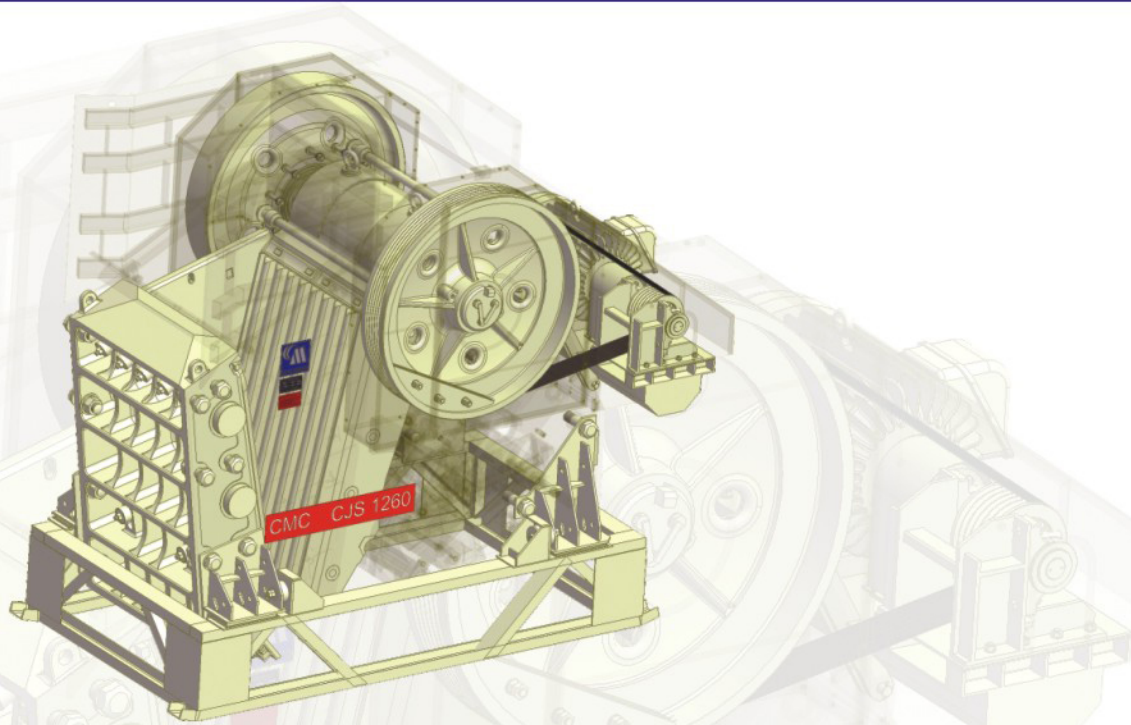

啓銘機械股份有限公司
CHYI MEANG MACHINERY CO., LTD.



目錄 Table of Content

獨特的優異特性及高性能	P2 . P4
Unique outstanding features and high performance	
高品質與高信賴度	P6
High quality and high reliability	
履帶移動式破碎站	P8
Crawler mobile crushing plant	
安裝和運行成本低	P10
Low installation and operation cost	
產能及技術參數	P12
Capacities and technical specifications	
尺寸及技術規格	P14
Dimension and technical information	

革命登場、全新發表

Revolutionary Crusher; New Presentation

反向破碎式顎碎機

UP-Thrust Jaw Crusher

本公司生產近40年岩石及礦山機械，一直以高產能、高性能、堅固耐用著稱，及持續不斷研發創新追求完善，永續經營。

CMC has produced rock crushing/screening equipments for nearly 40 years with name of high capacity, high performance and rock solid durable. By continuous R & D and innovation to pursue perfect, CMC achieves **sustainable business running**.

此機種擁有 5 大獨特之優異特性：(專利申請中)

1. 使用動力較同級機種減少約20-25%
2. 產能較同級機種增加約20%
3. 受齒使用時數增加約1~2倍 (同作業量)
4. 調整排礦口大小，不須鬆緊拉桿彈簧
5. 依使用需要，可調整大或小破碎行程

It has 5 unique outstanding advantages: (patents pending)

1. Power required decreases 20 – 25% about compared to equivalent models.
2. Capacity increases 20% about compared to equivalent models.
3. Life time of fixed Jaw plate increases 1-2 times. (in same operation condition)
4. No need to loosen and tighten tension rod spring while adjust discharge set.
5. Adjustable stroke for different material property.

本機種適合於各類應用，固定式，移動式，礦山井內，高海拔礦山等，交通搬運困難處。

It can fit for wide and different kinds of applications, stationary, portable, deep mining well, high sea level quarry and all other difficult transportation areas.

專利申請中(美、日、歐盟、台灣、中國、印度)
Patent pending (USA, Japan, European Union, Taiwan, China and India)

反向破碎運動
Up-Thrust crushing

作業所需動力來自電動機及皮帶輪飛輪之慣性產生動力破碎。

- 新型反向作動，以動齒總成重量下壓破碎可節省動力約20~25%。
- 動齒下壓破碎，使破碎物不易滑動增強破碎效果，產能增加約20%。
- 反向破碎動齒的作動角度，符合破碎原理，大大降低磨損率，受齒使用時數可增長約1~2倍。

上述革命性優異特性，為客戶提供最大的競爭優勢。

The required power for crushing comes from motor and inertia of flywheels.

- New up thrust crushing saves about 20-25% power due to the swing jaw assembly downward crushing action.
- Capacity increases 20% about due to the movable jaw plate downward crushing and increase crushing effect.
- Up thrust crushing action reasonably reduce the rub action on fixed jaw plate and increase the service life time of fixed jaw plate 1-2 times.

These Revolutionary advantages lead edge your business competitiveness.

破碎間隙自動調整機構
Automatic discharge set adjustment

複式油壓缸作動雙楔型塊產生分力推動各另件按順序動作，達到間隙調整的目的，由於連桿獨特組合方式，調整破碎間隙，不需鬆開拉桿彈簧。

Dual-acting hydraulic cylinders pushed or pull twin wedges and cause related parts move in sequence to achieve discharge set adjustment. Thanks to the unique link assembly, discharge set adjustment can be without loosen tension rod spring.

可調整破碎行程的偏心結構
Adjustable stroke by eccentric mechanism

依破碎物之性質可選擇適當之破碎行程，調整方式十分簡單，只須用隨機之特殊工具調整，如右圖偏心套的角度即可改變S板角度從而改變破碎行程

Optimum Stroke can be changed according to material property. The adjustment is very easy by special spanner shipped with crusher to change the angle of Eccentric Sleeve. And then angle of toggle plate changes accordingly and so as stroke.

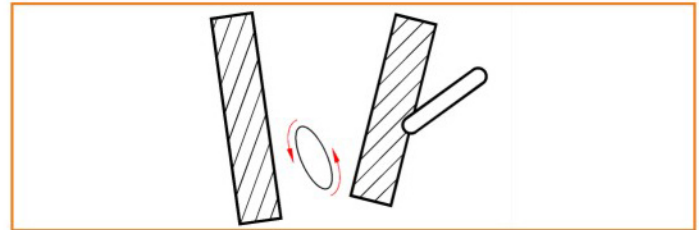

一般傳統型 Down-Thrust Type

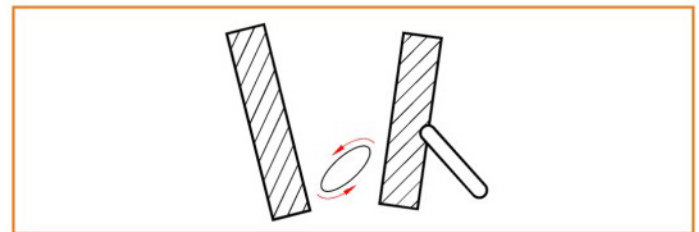

反向破碎型 Up-Thrust Type

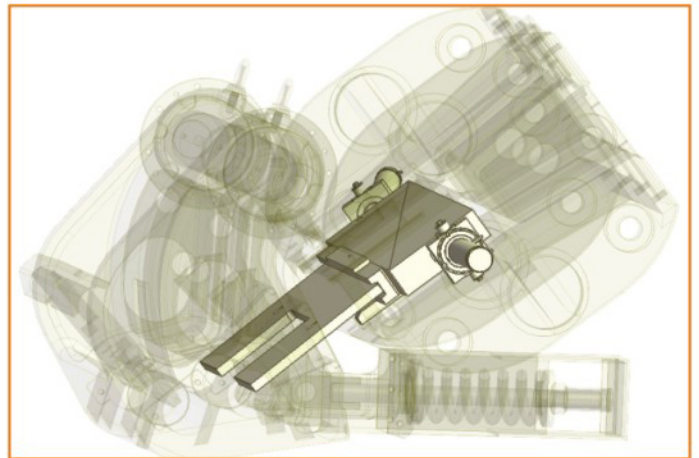

破碎間隙自動調整機構
Automatic discharge set adjustment

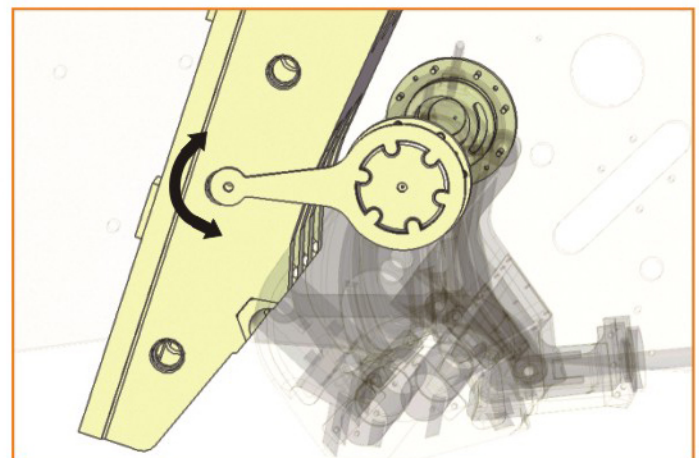

可調整破碎行程的偏心結構
Adjustable stroke eccentric sleeve mechanism

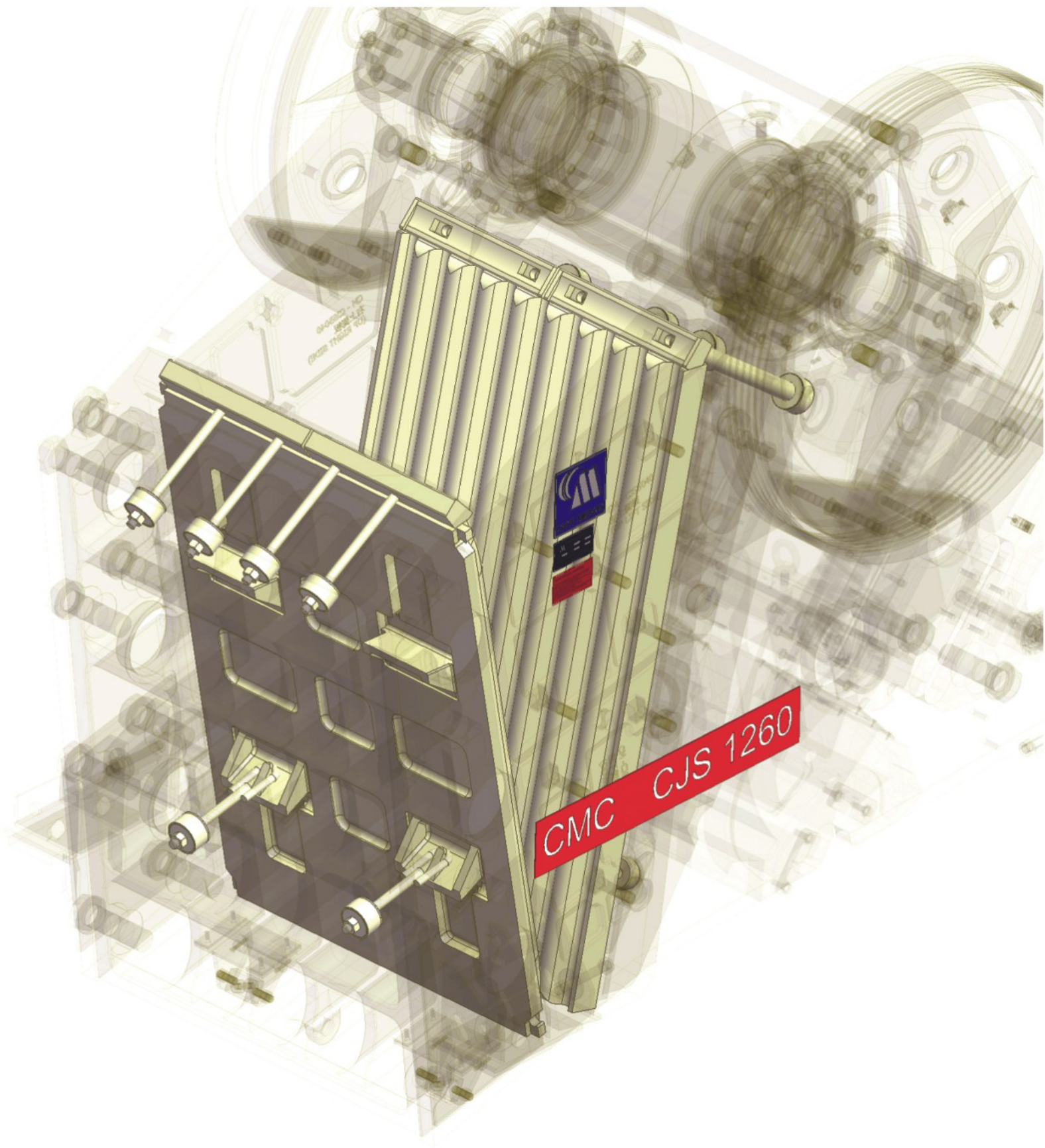

合適之破碎腔口設計 Suitable crusher cavity design

合適之破碎腔口配合入料槽，可避免最少堵料狀況，達到最佳破碎作業流程，入料槽用於有效保護活動座軸承避免破碎物直接撞擊及引導破碎物料進入破碎腔。

The suitable cavity design matched with feed chute avoids bridging of material and reaches best crushing operation. The functions of feed chute keeps Swing Jaw bearings area from material impact effectively and guide material smoothly feeding into crusher cavity.

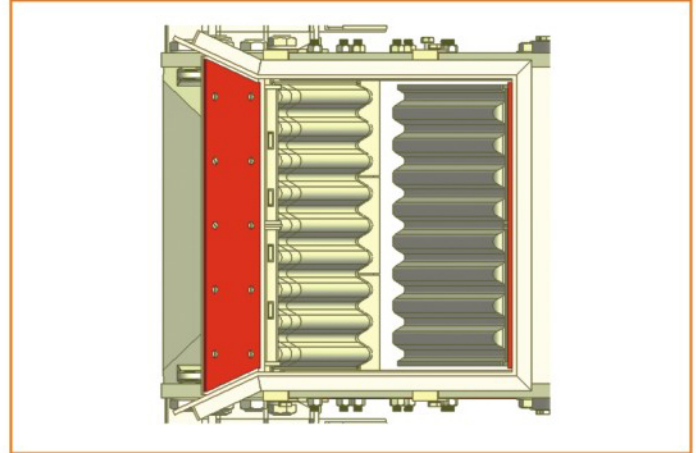

合適之破碎腔口配合入料槽
Suitable crusher cavity with feed chute

下料緩衝機構 Shock absorption mechanism for material discharge

在落料口下側，安裝一組下料緩衝機構，使破碎物落下時，避免直接衝擊輸送帶，防止損傷。

A shock absorption mechanism is installed at lower lateral side of discharge opening. It reduces direct impact of rock on under conveyors and protects conveyor from damage.

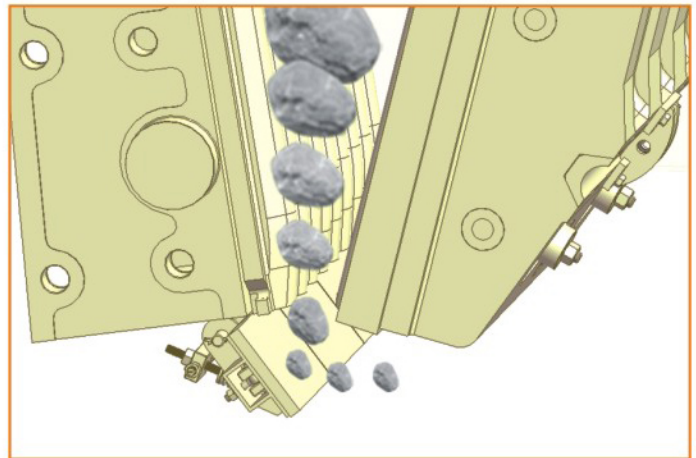

下料緩衝機構
Shock absorption mechanism for material discharge

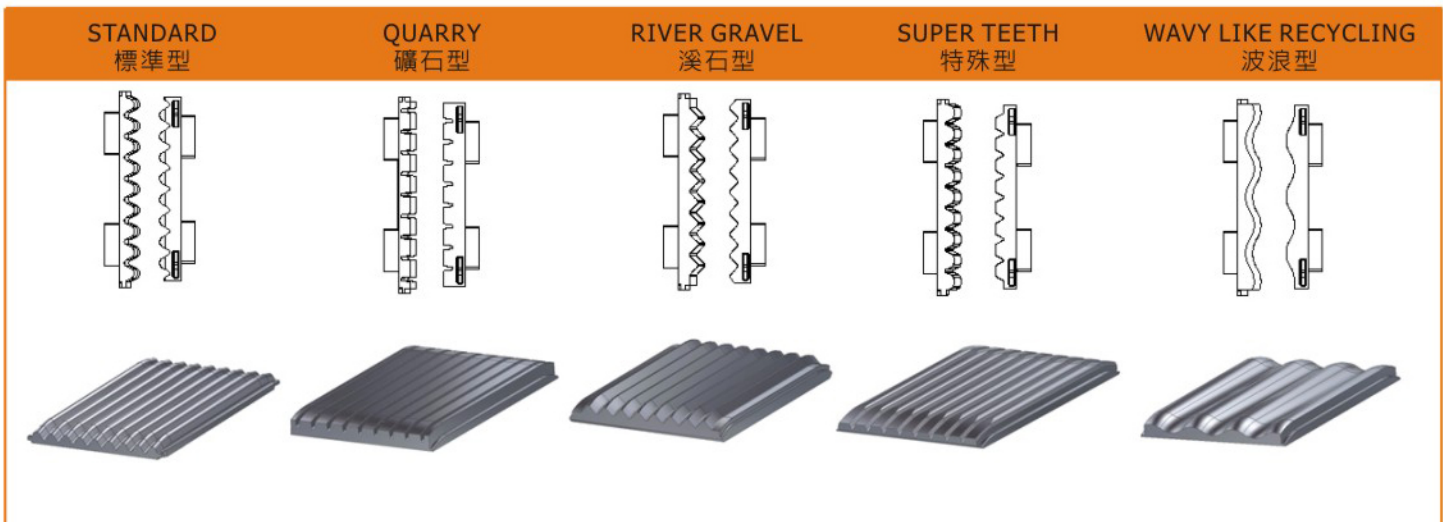



提供最耐用的軸承

The most durable bearings

CJS系列顎碎機，外軸承採用圓錐內孔軸承配合退卸套，具有與內軸承同等負載能力，而且在裝卸過程中更簡便。

Frame bearings are designed as spherical roller bearings with withdrawal sleeve in CJS series Jaw Crusher. Frame bearings have same load capability as Swing Jaw bearings. It is also easy assembly and disassembly in this design.

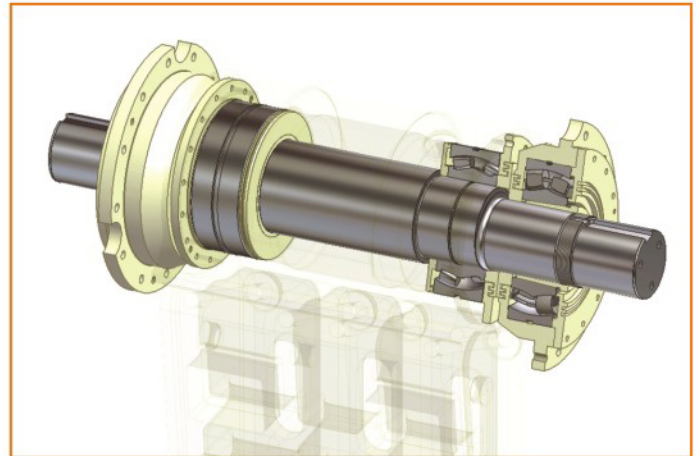

堅固的偏心軸軸承

Large and sturdy eccentric shaft bearings

高剛性軸承座結構設計

Excellent rigidity bearing seat assembly design

活動座總成採用高質量的鑄鋼件構成，並且在軸承座外圍平均分佈3組支撐桿，相當有效提供機台剛性穩定度，即使在嚴苛應用環境下，CJS系列產品皆能夠提供卓越的強度，可靠性。

The Swing Jaw is made of high quality cast steel and three support rods are designed to be evenly installed on the surrounding of bearing seat, which can provides excellent rigidity of frame. CJS series Jaw Crusher ensures greatest strength and reliability even under the most severe crushing condition.

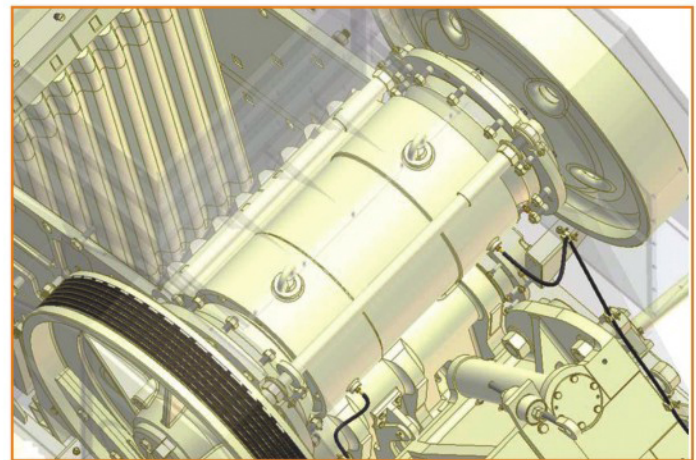

堅固的軸承座總成

Robust bearing seat assembly

模組化設計

Modular construction design

採用模組化設計和高精度加工組合結構，每個主要部件皆可單獨搬運，至現場組裝完成，特別適合於高海拔礦山、井下、交通運輸困難之場所。

A modular and high precise machining construction enables all major parts can be transported to site separately and assembled into whole. This is especially suitable for high sea level quarry, deep well mining and other transportation difficult areas.

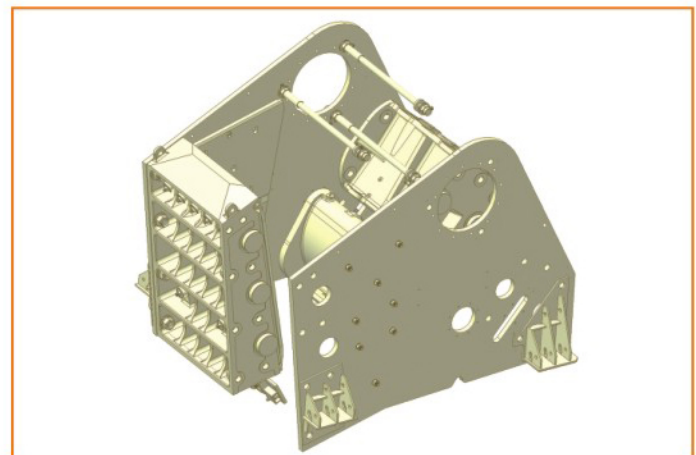

模組化設計

The modular construction

超低的進料作業高度
Ultra low Feeding Height

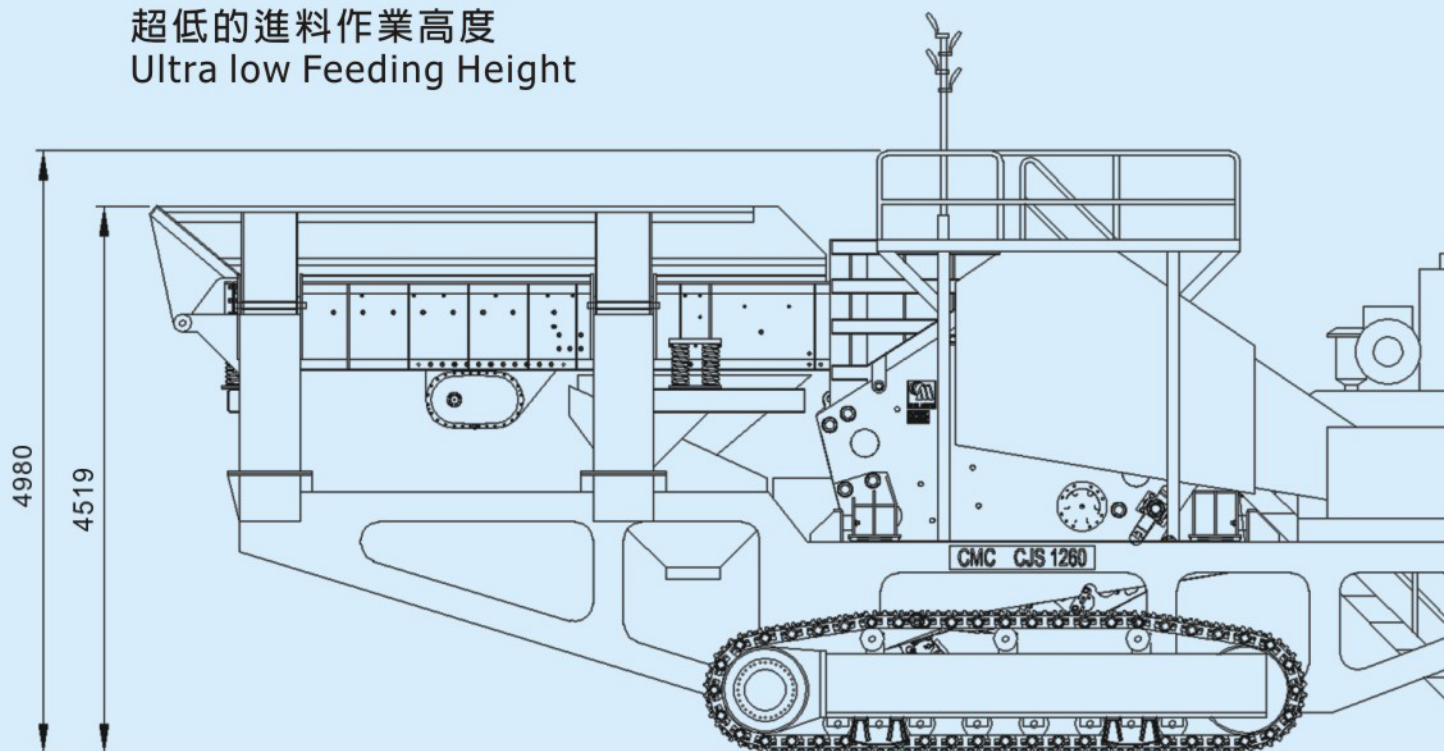

方便搬運，成本最低
Easy Transportation, Minimum cost

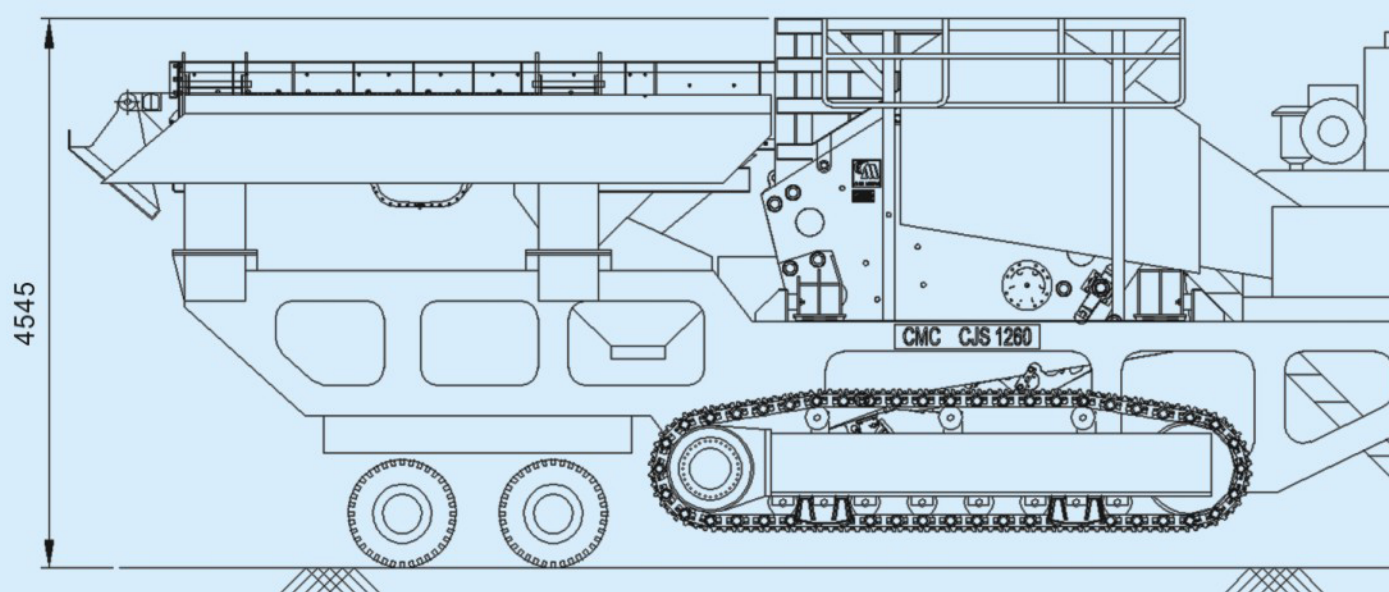

履帶移動式破碎站

Crawler mobile crushing plant

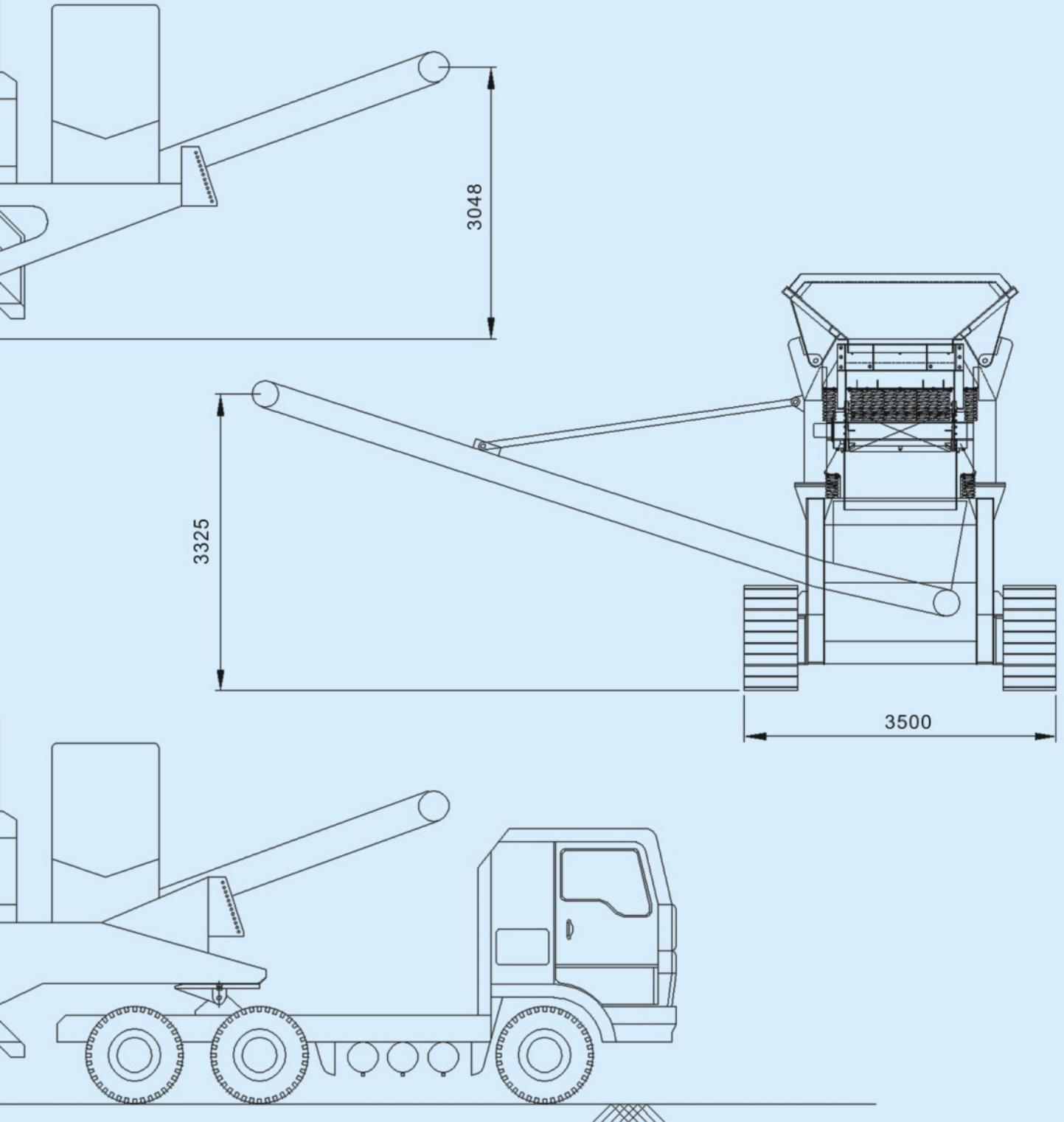



顎式破碎機基礎

Jaw Crusher foundation

本系列破碎機的橡膠減震裝置和限位塊可以通過吸收震動峰值載荷，並允許破碎機垂直和縱向位移，從而有效的降低了破碎機對基礎的衝擊，這種獨特和創新的安裝系統不需要基礎螺栓，變更腳架位置，可適用於移動式或固定式。

Rubber dampers and stoppers effectively decrease crushing loads to the foundation by absorbing peak shock loads and allowing crusher to move vertically and longitudinally. This unique and innovative system eliminates the need of anchor bolts. Change support position to meet portable or stationary application requirement.

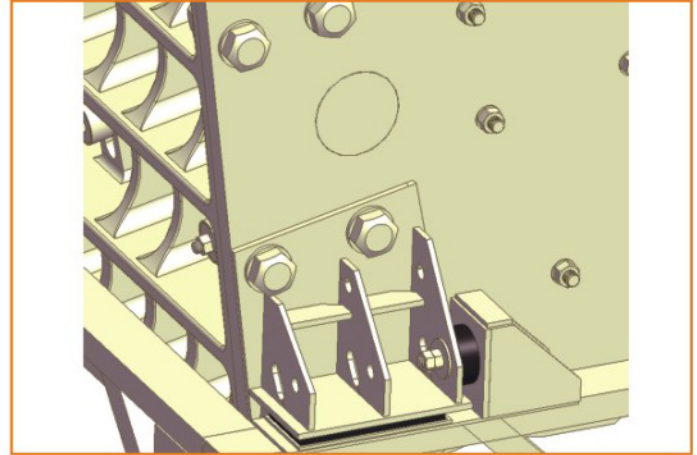

變更腳架位置，可適用於移動式或固定式
Change support position to meet portable or stationary application requirement

飛輪護罩結構簡潔便於保養

Compact flywheel guards

本系列顎式破碎機的飛輪護罩螺栓連結在破碎機邊板上，有效地保護破碎機操作者的安全。檢視窗和檢視門提供了方便，檢查皮帶張力。

Flywheel guards are bolted onto the crusher's side plates and effectively protect operators' safety. Viewing window and door provides easy inspection V-belts tension.

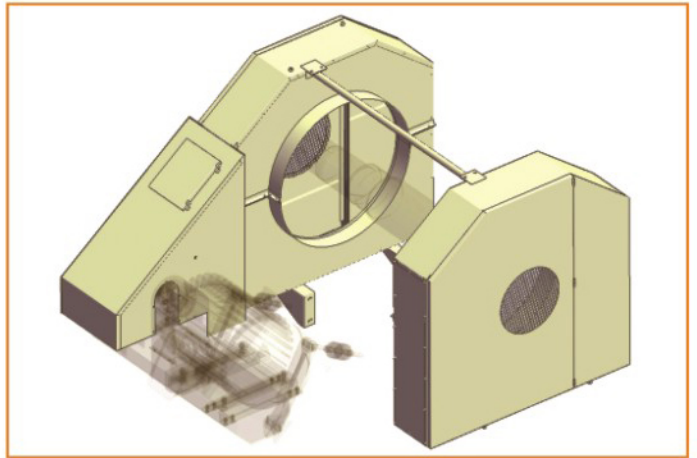

配合飛輪護罩，可減少對破碎機周圍的空間需求
The flywheel guards reduce space requirements around the crusher

廣泛的安裝應用

Wide installation applications

本系列顎式機不但重量輕，機台可更換腳架位置適合各種應用，且採用特殊反向破碎及可調整破碎行程機構產能高，馬力省廣泛適用於各種應用。

- 更換老式顎碎機，基礎不必改，且產能更大。
- 各種地面安裝，如採石、礦山、採礦坑及回收破碎。
- 履帶式或輪式移動式破碎站。

The series Jaw Crusher is not only light weight, support position can be changed for different application requirement. Also special Up-Thrust and adjustable crushing stroke design has advantages of high capacity, low power consumption. It can be widely suit for different applications:

- An ideal choice for the replacement of existing Jaw Crusher and modifications to the existing foundation are rarely required. The capacity is larger.
- Right choice for stationary surface installations at quarries, mines, gravel pits and even recycling plants.
- Hot choice for both crawler and wheeled type portable plants.





	CJS800	CJR900	CJS900	CJR1050	CJS1000	CJS1100	CJR1350	CJS1200	CJS1260	CJS1400	CJS1500	CJS2000	
給料口寬度mm Feed opening width mm(in)	800(32)	900(36)	900(36)	1050(42)	1000(40)	1100(44)	1350(54)	1200(48)	1260(50)	1400(56)	1500(60)	2000(80)	
給料口深度mm Feed opening depth mm(in)	500(20)	500(20)	600(24)	700(28)	800(32)	850(34)	750(30)	900(36)	1000(40)	1100(44)	1250(50)	1500(60)	
電動機功率HP Power HP	75	100	100	150	150	175	175	200	200	250	300	500	
電動機功率Kw Power Kw	55	75	75	110	110	130	130	150	150	190	225	375	
轉速(rpm) Speed(rpm)	350	350	320	270	270	250	270	240	240	220	220	200	
產品尺寸 Product Size	閉口間隙 Closed side setting	Mtph	Mtph	Mtph	Mtph	Mtph	Mtph	Mtph	Mtph	Mtph	Mtph	Mtph	
mm(in)	mm(in)	Stph	Stph	Stph	Stph	Stph	Stph	Stph	Stph	Stph	Stph	Stph	
0-30	20												
0-1 1/8	3/4												
0-35	25												
0-1 3/8	1												
0-45	30												
0-1 3/4	1 1/8												
0-60	40	66-90	88-111										
0-2 3/8	1 5/8	73-99	97-122										
0-75	50	80-117	106-133										
0-3	2	88-129	117-147										
0-90	60	94-137	125-156	114-145									
0-3 5/8	2 3/8	104-151	138-171	126-160									
0-105	70	108-157	143-178	131-166	171-215	161-206	184-224	216-283					
0-4 1/8	2 3/4	119-173	158-196	145-183	189-237	177-227	202-247	238-312					
0-120	80	122-177	162-201	148-187	193-242	181-232	206-251	243-306					
0-4 3/4	3 1/8	134-195	178-221	163-206	213-266	200-255	227-277	268-337					
0-135	90	136-197	181-223	165-208	215-269	202-257	229-278	271-340					
0-5 3/8	3 1/2	150-217	199-246	182-229	237-296	222-283	252-307	298-374					
0-150	100	150-217	199-246	182-229	237-295	222-282	252-306	298-373	250-320	265-348			
0-6	4	165-239	219-271	201-252	261-325	244-311	278-336	328-411	276-352	292-383			
0-185	125	185-267	245-302	225-281	291-362	273-345	309-373	366-457	307-391	325-425	400-511		
0-7 3/8	5	204-294	270-333	247-309	321-399	300-380	340-411	403-503	338-431	358-468	441-563		
0-225	150	220-317	292-358	267-333	346-429	323-408	366-441	434-540	364-462	385-501	473-602	550-707	
0-9	6	242-349	321-395	294-367	381-472	356-450	403-486	478-595	401-509	424-552	521-663	606-778	
0-265	175	255-366	338-415	309-386	400-495	374-471	423-509	502-624	421-533	445-578	546-693	635-813	789-984
0-10 5/8	7	280-403	372-457	341-425	441-545	412-519	466-561	533-687	464-587	490-637	601-764	699-895	868-1084
0-310	200				455-562	425-534	480-577	570-707	478-604	505-655	619-785	719-919	892-1111
0-12 3/8	8				501-619	468-588	529-636	628-779	526-666	556-721	682-864	792-1012	982-1224
0-350	225								535-675	565-732	692-876	803-1025	996-1238
0-14	9								589-744	622-806	762-965	885-1129	1096-1364
0-380	250								592-747	625-808	765-967	888-1132	1099-1365
0-15 1/8	10								651-822	688-890	842-1065	978-1246	1210-1503
0-420	275											972-1238	1202-1492
0-16 3/4	11											1071-1363	1324-1643
0-460	300											1057-1344	1306-1619
0-18 3/8	12											1164-1480	1438-1783

上表所表示的破碎機產能乃針對破碎行程在中間值的一般性物料。對於破碎行程調至最大值的易碎性物料(如煤炭或玻璃)，產能約多12%，破碎行程調至最小值的堅韌物料(如鐵燧岩)產能約少10%。

上表數據指入料能夠順利進入破碎腔，無卡料現象，產量可能隨入料方式，物料性質諸如粒度組成、含水含泥量、鬆散密度和可碎性而變化。

以下因素可提高破碎機的能力和性能：

1. 適合的齒板選擇。
2. 適合的入料級配。
3. 可控的入料量。
4. 足夠的飼料機能力和給料寬度。
5. 充分的破碎機排料區。
6. 排料輸送帶與破碎機最大能力相匹配。

The capacities shown above is referred to usual material with stroke set at middle value. As for brittle material with stroke set at maximum value (e.g. coal and glass), capacity is up about 12% and material with stroke set at minimum value (e.g. taconite), capacity is down about 10%. The above figures are based feed material enters crusher cavity without bridging. The capacities may vary depending on the feeding material and on feed characteristics such as gradation, bulk density, moisture, clay content and crushability. The following factors will enhance crusher capacity and performance:

1. Proper selection of jaw plates.
2. Proper feed gradation.
3. Controlled feed rate.
4. Sufficient feeder capacity and width.
5. Adequate crusher discharge area.
6. Discharge conveyor sized to conveyor maximum crusher capacity.

粒度特徵曲線

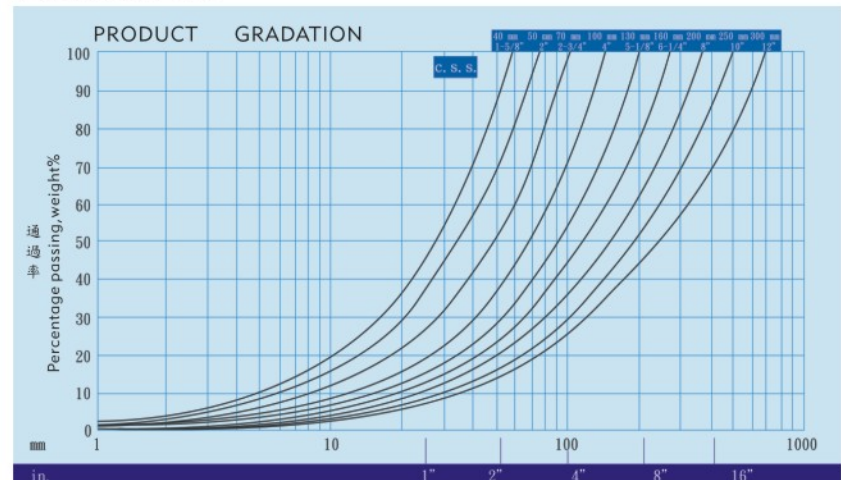

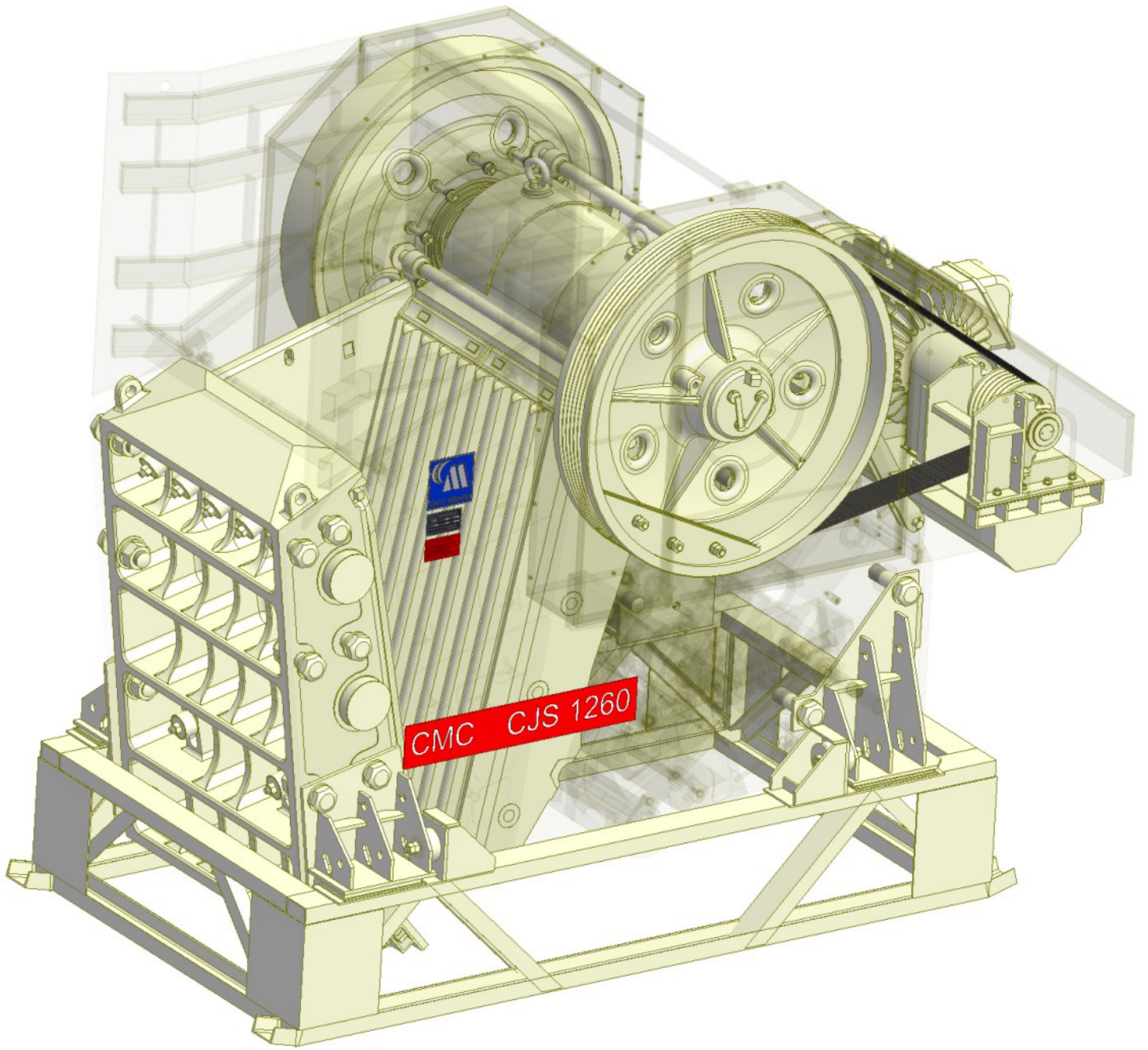

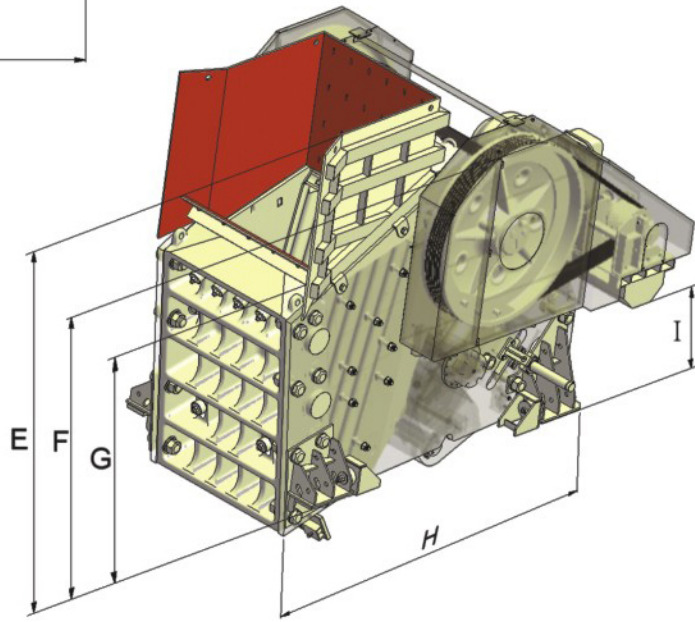
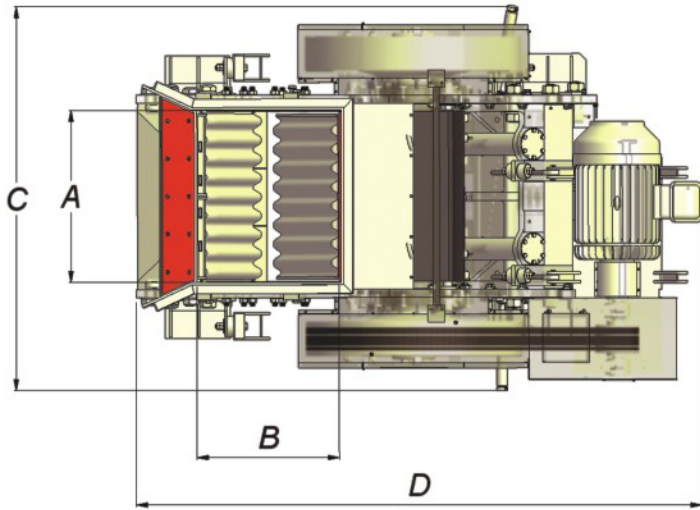

外型尺寸和重量
Dimension and weights

		CJS800	CJ R900	CJS900	CJR1050	CJS1000	CJS1100	CJR1350	CJS1200	CJS1260	CJS1400	CJS1500	CJS2000
A	mm (in)	800 (32)	900 (36)	900 (36)	1050 (42)	1000 (40)	1100 (44)	1350 (54)	1200 (48)	1260 (50)	1400 (56)	1500 (60)	2000 (80)
B	mm (in)	500 (20)	500 (20)	600 (24)	700 (28)	800 (32)	850 (34)	750 (30)	900 (36)	1000 (40)	1100 (44)	1250 (50)	1500 (60)
C	mm (in)	1755 (69)	1865 (73.5)	1925 (75.8)	2210 (87)	2185 (86)	2375 (93.5)	2650 (104.3)	2515 (99)	2565 (101)	3125 (123)	3300 (130)	4300 (169.3)
D	mm (in)	2200 (86.6)	2620 (103)	2860 (112.5)	3400 (133.9)	3720 (146.5)	4000 (157.5)	3520 (138.6)	4275 (168.3)	4335 (170.6)	5060 (199.2)	5700 (224.4)	6760 (266)
E	mm (in)	1740 (68.5)	1740 (68.5)	2045 (80.5)	2325 (91.5)	2750 (108.3)	2905 (114.4)	2545 (100)	3065 (120.6)	3165 (124.6)	3665 (144.3)	4140 (163)	4935 (194.3)
F	mm (in)	1625 (64)	1625 (64)	1890 (74.5)	2170 (85.5)	2450 (96.5)	2650 (104.3)	2425 (95.5)	2775 (109.3)	2850 (112.2)	3335 (131.3)	3650 (143.7)	4510 (177.5)
G	mm (in)	1050 (42)	1050 (42)	1220 (48)	1355 (53.3)	1600 (63)	1700 (67)	1500 (60)	1800 (70.8)	1835 (72.2)	2120 (83.5)	2400 (94.5)	2860 (112.6)
H	mm (in)	2120 (83.5)	2120 (83.5)	2300 (90.5)	2760 (108.7)	3050 (120)	3250 (128)	2875 (113)	3415 (134.4)	3465 (136.4)	4135 (162.8)	4680 (184.2)	5535 (218)
I	mm (in)	550 (22)	550 (22)	550 (22)	700 (28)	750 (30)	800 (32)	700 (28)	950 (38)	985 (39)	1135 (45)	1285 (51)	1530 (61)
破碎機自重 Crusher weight without options	kg Lbs	7860 17292	8980 19756	9820 21604	13970 30734	19890 43758	25530 56166	25780 56716	37250 81950	37500 82500	55490 122078	69880 153736	119540 262988
破碎機總重 (含選配件) Total crusher weight	kg Lbs	9765 21483	11035 24277	12025 26455	16620 36564	22950 50490	29030 63866	30180 66396	39780 87516	40030 88066	64690 142318	82350 181170	135190 297418

啓銘機械可提供破碎機總體佈置、基礎和維修空間要求的詳細圖紙

General arrangement, foundation and service space requirement drawings are available from CMC

對客戶的承諾 啓銘責任的開始

Commitment for customers is the start of CMC'S responsibility

■ 啓銘機械自1969年由董事長簡正旭先生創立以來，數十年來，啓銘堅持“品質、服務、創新”的經營理念以及精益求精的精神，不斷在產品技術製程上致力改善，追求碎石設備之現代化、先進化及生產流程簡單化、一貫化以滿足客戶的需求，範圍涵蓋整廠碎石設備諮詢的規劃、設計、安裝、售後服務及操作訓練。

一本以往精神，傾聽客戶的需求，追求更先進技術，致力產品國際化，期能為客戶創造更大利益，為社會建設做出更多的貢獻。

■ Since CMC (Chyi Meang Machinery Co.,Ltd) was founded in 1969 by Mr. Jean Hsu Chien, For decades, CMC insists "Quality, Service, Innovation"-company motto and the spirit of pursuing better on better in continuous improvement on product technology and manufacture facilities/process.CMC has devoted to the modernization of stone crusher and the production process simplification/centralization to meet customer satisfaction. Our ranges cover consultancy, planning, design, manufacture, installation, after sales service and training of complete stone crusher plant equipments.

CMC keeps same spirit as usual,pursues more advance technology,devote to products' internationalization. CMC endeavors to create maximum advantages for clients.

桃園廠 Main Office & Factory (Taoyuan)

桃園縣八德市介壽路二段535號
No. 535 Chieh-Shou Rd. Sec. 2. Pate
City Taoyuan Hsien Taiwan
Tel : 886-3-3666167-9
Fax : 886-3-3668366



雲林廠 Office & Factory (Yunlin)

雲林縣林內鄉重興村68之50號
No. 68-50, Chongsing Village,
Yunlin County, Taiwan
Tel : 886-5-5890167-8
Fax : 886-5-5890169



屏東廠 Office & Factory (Pingtung)

屏東縣里港鄉三和路119之66號
No. 119-66, Sanhe Rd., Ligang Township,
Pingtung County, Taiwan
Tel : 886-8-7733735,7733730
Fax : 886-8-7733732



中國廈門廠 Office & Factory (Xiamen)

福建省龍海市龍池開發區
鴻漸工業園橫二路4之1號
No.4-1 , Heng Erh Road, Hong Jian
Industrial Park, Long Chi Development
Zone, Long Hai City, Fujian Province
Tel :86-596-6769-799
Fax :86-596-6769-199



啓銘機械股份有限公司
CHYI MEANG MACHINERY CO., LTD.

E-mail : sales@chyimeang.com

[http : //www.chyimeang.com](http://www.chyimeang.com)

Agent/Distributor: